

General Course Goals

B What are the overarching goals of your course?

Performance 0 V U P D N F T

B Each module will have P V U D P N F T that you desire for your students to achieve. These should be measurable.

Learning 0 C K F D U J W F T

B These are the assignments that students will need to complete to demonstrate proficiency in learning the material.

The sample Course Blueprint below will assist you in visualizing how you can design your own Course Blueprint. Note how the above elements relate to the structure in the sample.

Sample Course Blueprint - American History 1877 - Present

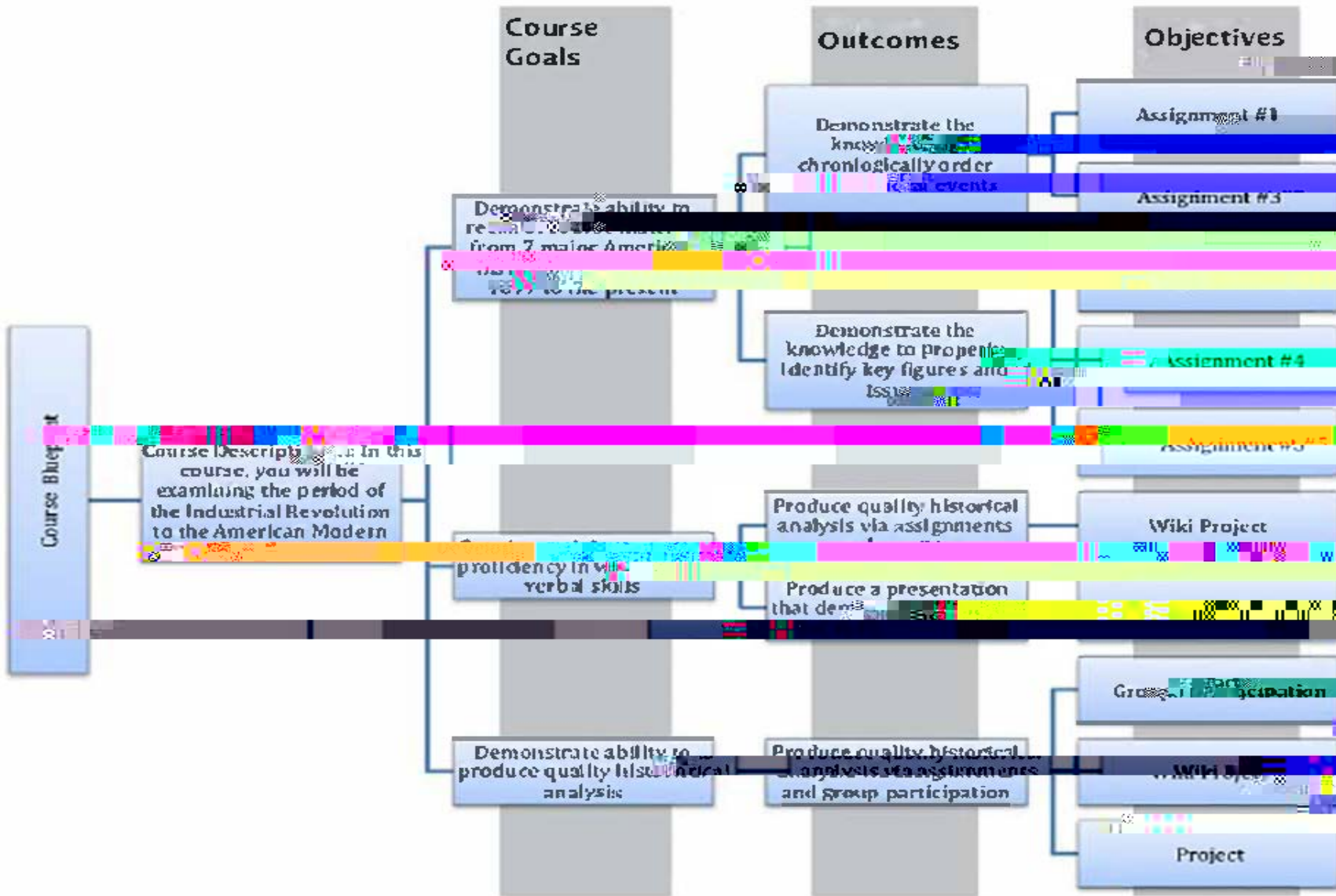

This Course Blueprint is part of the [Blended Learning Toolkit](#) prepared by the [University of Central Florida](#) (UCF) and the [American Association of State Colleges and Universities](#) (AASCU) with funding from the [Next Generation Learning Challenge](#) (NGLC). It is provided as an open educational resource under a [Creative Commons Attribution-NonCommercial-ShareAlike 3.0 Unported License](#).

Course Blueprint- Course Title

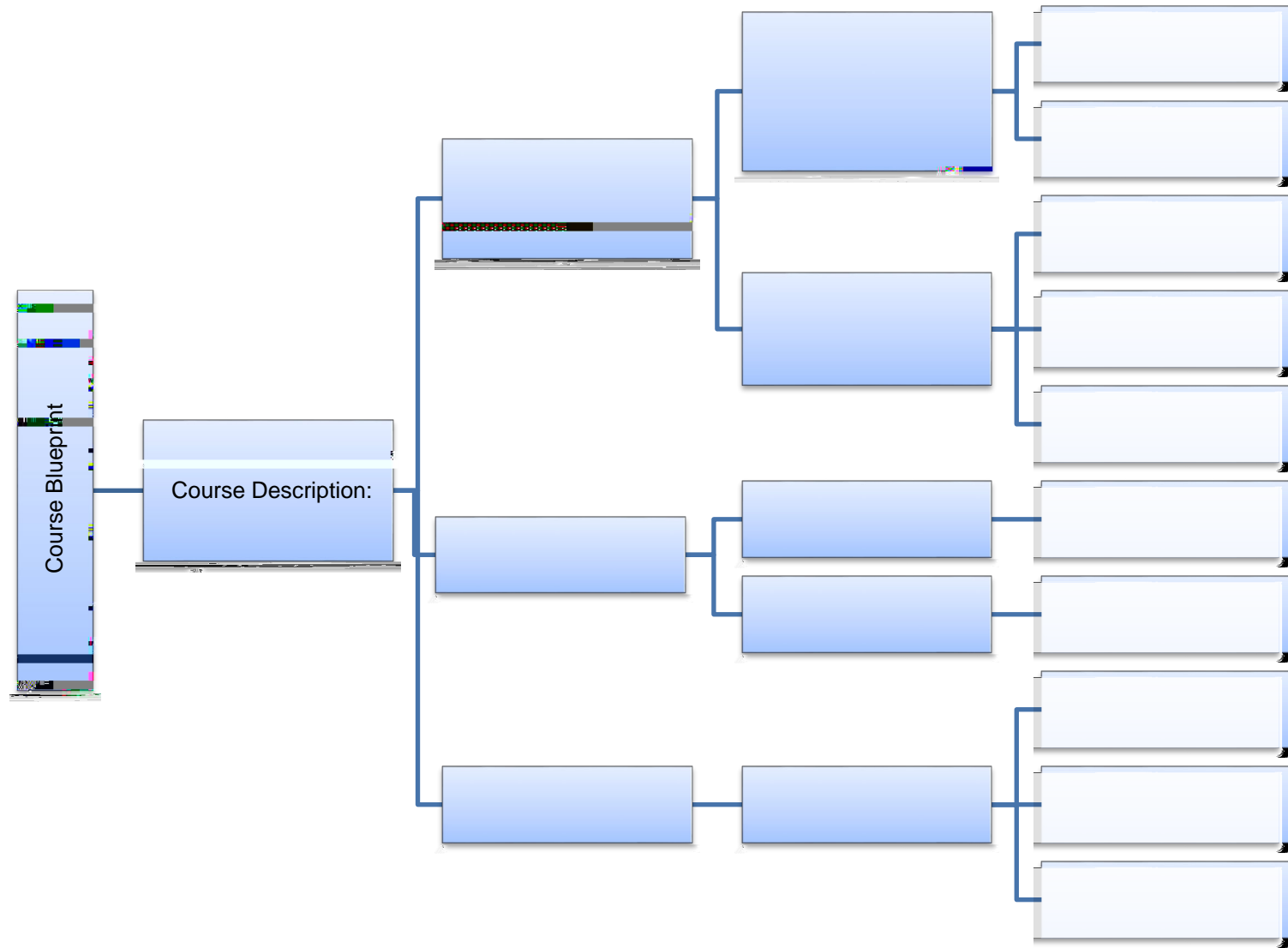

Course Blueprint in Practice: Comparing Content of Syllabus and Modules